



INSTALLATION INSTRUCTIONS : AEC12-12-30 Unit

ELECTRIC VEHICLE / ELECTRIC HYBRID VEHICLE – EV AUXILIARY BATTERY TO BATTERY CHARGING SYSTEMS.

The AEC12-12-30 EV charger maximises the range of the vehicle by fully charging the auxiliary battery when the traction batteries are being charged and while driving it only tops up the auxiliary battery in defined necessary situations . This is all to maximise the range from the traction battery. The AEC12-12-30 can use EV ECU signals ,EV chassis battery voltage levels, an Ablemail AES-001 Advanced AC/DC charging detector, a CAN interface signal or any available mains charging indicator signal to ensure the auxiliary battery is fully charged while the charging of the vehicle traction batteries is completed. The AEC12-12-30 has been designed to charge up to 300Ahr of most battery types including AGM, GEL, Flooded and LITHIUM. A bluetooth module is built into the charger so battery selection and programme configuration can be carried out using a Android or IOS mobile device & the Ablemail Device Manager App .

The AEC12-12-30 then only charges the auxiliary battery in an emergency situation or to a specific state of charge percentage when driving or parked (without vehicle mains charging) in order to have no / minimal impact on range. The programmeability of the AEC12-12-30 means it can be optimised to solve the issues of auxiliary 12 Volt DC battery charging on full electric and electric hybrid vehicles in most installations. This AEC12-12-30 works with electric vehicle AC chargers & rapid vehicle DC chargers and for most applications a single AES-001 sensor located on the battery charging feed is sufficient .

Mounting The EV Auxiliary Battery Charger Main Unit. AEC12-12-30

Take all relevant precautions when installing the EV auxiliary battery charger unit, drilling & screw fixing of the unit to avoid damage to hidden vehicle components, vehicle high voltage battery packs, cables & wiring, Failure to correctly install the EV charger unit could result in damage to electric vehicle, components, EV auxiliary battery charger unit, electric vehicle & auxiliary batteries, cables & wiring & is not covered under the unit warranty terms & conditions of the EV charger unit & Ablemail Electronics hold no liability on vehicle or unit installation . The installation should only be carried out when the vehicle is not connected to a EV charging point . The installation should be completed by a qualified installation engineer

!!! MAKE SURE ANY SECURING SCREWS DO NOT PIERCE THE HIGH VOLTAGE VEHICLE BATTERY !!!

!!! THE AEC12-12-30 IS NOT WEATHERPROOF (NOT IP65) SO DO NOT POSITION WITH EXPOSURE TO THE THE ELEMENTS !!!

!!! THE AEC12-12-30 RUNS HOT SO ALLOW SOME MEANS TO PREVENT HEAT BUILD UP !!!

The unit is fully protected from thermal overheating, the EV auxiliary battery charger unit will automatically turn off or enter low current charging capacity when required until the operating temperature of the unit falls below the maximum efficient operating temperature of the unit

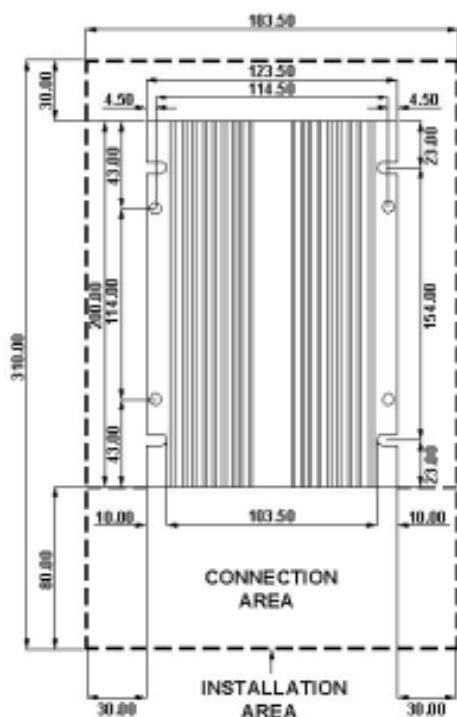

NOTES:

1. 4off fixing holes 6.50mm Ø.
2. 4off slots 6mm x 10mm.
3. Recommended air space around heatsink:- top, sides and non connector end 30mm (as dashed lines).
4. Connector end space 80mm absolute min (as dashed lines).
5. Recommended mounting:- metal base.
6. Orientate Led for visibility.
7. Do not fit near heat sensitive material or components as case may reach temperatures up to 75 deg C.
8. Do not fit near heat sources such as exhaust or heater pipes.

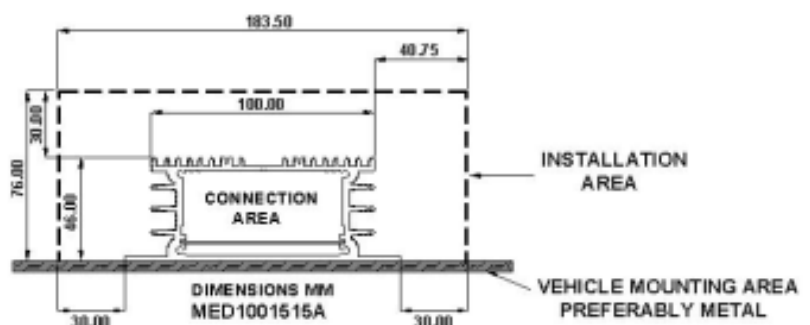

EV AUXILIARY BATTERY CHARGER CABLE CONNECTION & FUSING.

IMPORTANT INFORMATION !!!

Caution For use on 12 Volt DC Electric Vehicle / Electric Hybrid Vehicles ONLY.

It is the sole responsibility of the EV charger unit installer to fit the correct system cable, wiring, fuses, quality fuse holders into the installation to protect the electric vehicle, EV charger unit, cabling, wiring, electric vehicle, and auxiliary batteries of the system installation. Failure to correctly install the EV charger unit could result in damage to electric vehicle, components, EV charger, electric vehicle and auxiliary batteries, cables & wiring & is not covered under the unit warranty terms & conditions of the EV charger unit & Ablemail Electronics hold no liability on vehicle or unit installation.

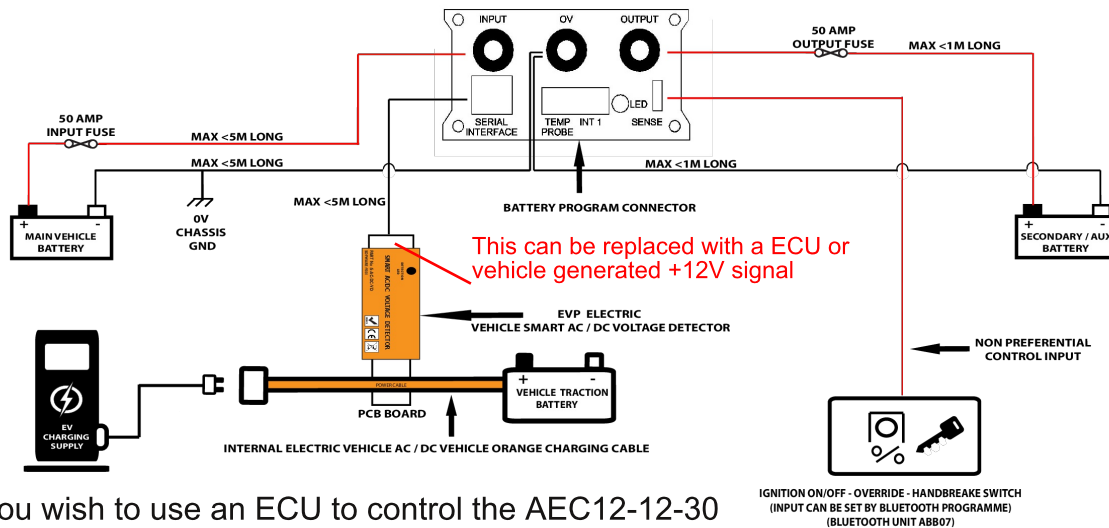

If you wish to use an ECU to control the AEC12-12-30 see AES-001 Installation Instructions DWG A

Connection Procedure / Power up Sequence: To ensure normal operation:

1. The secondary battery must be connected first to the charger output & common ground.
2. Then the charger input & sense input (if fitted) can be connected to the vehicle primary battery. We recommend fitting a short link from +ve input to the sense input .
3. When mains charging to the vehicle traction battery is occurring a +12V signal must be applied to the charger through pin 4 on the serial interface adaptor or an AES001 must be connected to the RJ12 input on the AEC12-12-30. The AES001 must be set up using the AES001 installation instructions

Operation:

Each charger operates as described below:

- The charger operates with an input voltage between 9V & 32V.
- The AES001 or vehicle ECU controls the charger turning on/off according to the configuration. The AES001 green led illuminates when the vehicle is mains charging & turns the AEC12-12-30 on, charging the Auxiliary battery. The charger Led flashes amber or green depending on the state of charge of the auxiliary battery . (Flashing Amber less than 80% charged , Flashing Green more than 80% charged)
- The output current is limited at 30A for each charger . There are 2 30A chargers built into a 60A charger .
- In case of a low input voltage (<9V), the output voltage is reduced to 0V preventing damage to the charger.
- The charger is protected against overheating & resets when it cools down.
- When the vehicle is driving the charger charges the auxiliary battery to a specified state of charge (usually 40%) . To achieve this the charger stops charging for 5s every 60s to check the state of charge of the secondary battery .

NOTE: The LED shows the charger state:

- Flashing Red - In fault mode
- Flashing Amber - Battery flat ;constant current/bulk charging at 14.1V(12V secondary battery) 28.2V (24V secondary battery).
- Flashing Green - Battery charged; float charging at 13.8V (12V secondary battery) 27.6V (24V secondary battery).

Fault Finding

- The Ablemail Device Manager App allows the charger settings and readings to be compared and amended . Key values to check are ; Local Input voltage is above the Vehicle Battery Guard Voltage and Local Output voltage is below the Leisure Battery Threshold
- If the charger fails to switch off within 1 minute of Mains Signal being removed check the Charger On and Off Duration using the App arger operates for 1 minute when ignition is applied , and runs on for 1 minute after mains signal is Check +app device settings are correct

Optional Extras available with all units :

The AES001 AC and DC mains charging sensor is often used with the AEC12-12-30 . The Ablemail Device Manager App from the IOS Apple Store or Google Play store can be used to make sensitivity adjustments to the AES001 as well as the AEC12-12-30 settings . The AES002 is a waterproof version of the AES001 for use in exposed environments . An AEC12-12-60 can be used in applications requiring a higher charging current .

If you require any assistance or advice on this product & or its safe integration with other electrical equipment, Please contact Ablemail Technical on +44(0)161 745 7697. Installation Instructions SWI054 Rev B 2/2